

TCD 2013

for power generating sets

100/135 - 251/260 kW at 1500/1800 rpm

EU Stage IIIA

- Watercooled 4 or 6-cylinder inline engines with turbocharging and charge air cooling.
- The powerful DEUTZ Common Rail (DCR[®]) injection system and the electronic engine control (EMR 4) with intelligent link to the drive management ensure optimum engine performance at low fuel consumption.
- Wet cylinder liners, long oil change intervals and easy changing of the engine fluids reduce the running costs and increase the availability of the machinery.

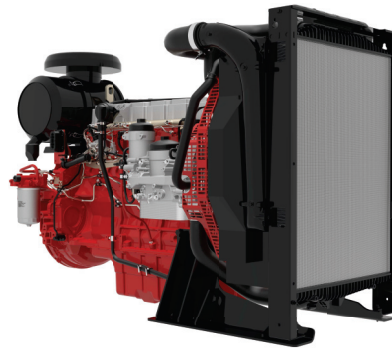

- Low noise emissions due to acoustically optimized components with very smooth running and high durability.
- Easy, inexpensive installation due to minimum weight and small installation space.
- Air filter and cooling system are fully pre-assembled.
- Best cold starting performance even under extreme conditions.
- The TCD 2013 meets the requirements of EU Stage IIIA.

Technical data

Engine type		TCD 2013 L4 2V	TCD 2013 L6 2V	TCD 2013 L6 4V
No. of cylinders		4	6	6
Bore/stroke	mm in	108/130 4.3/5.1	108/130 4.3/5.1	108/130 4.3/5.1
Displacement	l cu in	4,8 293	7,2 439	7,2 439
Weight with cooling system and air filter	kg lb	660 1455	945 2083	955 2105
Governing standard ⁵⁾		G2	G3	G3

50 Hz / 1500 rpm

Power output ¹⁾		TCD 2013 L4 2V	TCD 2013 L6 2V	TCD 2013 L6 4V
LTP ²⁾ - gross (no fan)	kW hp	100 135	151 202	251 336
LTP - net flywheel	kW hp	98 131	146 196	242 324
PRP ³⁾ - gross (no fan)	kW hp	95 128	144 192	238 319
COP ⁴⁾ - gross (no fan)	kW hp	90 121	136 182	226 303

60 Hz / 1800 rpm

Power output ¹⁾		TCD 2013 L4 2V	TCD 2013 L6 2V	TCD 2013 L6 4V
LTP ²⁾ - gross (no fan)	kW hp	114 153	174 233	260 349
LTP - net flywheel	kW hp	110 147	165 221	245 328
PRP ³⁾ - gross (no fan)	kW hp	109 146	165 221	247 332
COP ⁴⁾ - gross (no fan)	kW hp	103 138	156 209	234 314

1) Power (kW) according to ISO 14396.

2) Limited Time Running Power: For up to 500 h/year, thereof a maximum of 300 h/year continuous running.

3) Prime Power: Average power output ≤ 80%, no time limitation, plus 5% additional power for governing purpose only.

4) Continuous Power: No time limitation, plus 10% additional power for governing purpose only.

5) According to ISO 8528-5.

The data on this data sheet are for information purposes only and are not binding values. The data in the quotation is definitive.

50 Hz / 1500 rpm

Fuel consumption ¹⁾		TCD 2013 L4 2V	TCD 2013 L6 2V	TCD 2013 L6 4V
Fuel consumption 25% load	g/kWh lb/hph	318 0.52	260 0.43	253 0.42
Fuel consumption 50% load	g/kWh lb/hph	284 0.47	249 0.41	235 0.39
Fuel consumption 75% load	g/kWh lb/hph	270 0.44	236 0.39	225 0.37
Fuel consumption 100% load	g/kWh lb/hph	244 0.40	216 0.36	210 0.35
Heat balance & cooling system		TCD 2013 L4 2V	TCD 2013 L6 2V	TCD 2013 L6 4V
Heat dissipation (engine radiator) ²⁾	kW hp	50 67	74 99	133 178
Heat dissipation (CAC) ²⁾	kW hp	19 25	23 31	39 52
Heat dissipation (convection)	kW hp	9 12	14 19	23 31
Fan power	kW hp	3 3	5 7	9 12
Cooling air flow	m ³ /h cfm	6480 3814	11500 6769	15480 9111
Inlet & exhaust data		TCD 2013 L4 2V	TCD 2013 L6 2V	TCD 2013 L6 4V
max. intake depression	mbar psi	10 0.15	10 0.15	10 0.15
Combustion air volume	m ³ /h cfm	450 265	600 353	756 445
max. exhaust gas temperature	°C °F	530 986	485 905	515 959
Exhaust gas flow	m ³ /h cfm	1261 742	1587 934	2079 1224

60 Hz / 1800 rpm

Fuel consumption ¹⁾		TCD 2013 L4 2V	TCD 2013 L6 2V	TCD 2013 L6 4V
Fuel consumption 25% load	g/kWh lb/hph	318 0.52	288 0.47	255 0.42
Fuel consumption 50% load	g/kWh lb/hph	282 0.46	260 0.43	234 0.38
Fuel consumption 75% load	g/kWh lb/hph	263 0.43	243 0.40	245 0.40
Fuel consumption 100% load	g/kWh lb/hph	233 0.38	223 0.37	218 0.36
Heat balance & cooling system		TCD 2013 L4 2V	TCD 2013 L6 2V	TCD 2013 L6 4V
Heat dissipation (engine radiator) ²⁾	kW hp	57 76	73 98	141 189
Heat dissipation (CAC) ²⁾	kW hp	20 27	26 35	46 62
Heat dissipation (convection)	kW hp	10 13	16 21	24 32
Fan power	kW hp	4 6	9 12	16 21
Cooling air flow	m ³ /h cfm	7560 4450	13320 7840	18720 11018
Inlet & exhaust data		TCD 2013 L4 2V	TCD 2013 L6 2V	TCD 2013 L6 4V
max. intake depression	mbar psi	20 0.29	20 0.29	20 0.29
Combustion air volume	m ³ /h cfm	492 290	660 388	858 505
max. exhaust gas temperature	°C °F	540 1004	511 952	485 905
Exhaust gas flow	m ³ /h cfm	1396 822	1806 1063	2270 1336

- 1) Refers to diesel with a density of 0.835 kg/dm³ at 15°C | 6.96 lb/US gallon at 60°F.
 2) The heat quantities are valid for the dimensioning of the cooling system.

Dimensions

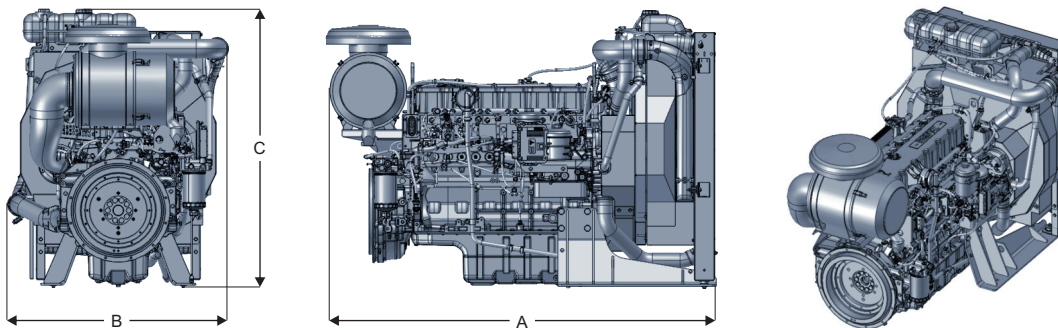

		A	B	C
TCD 2013 L4 2V	mm in	1589 62.6	880 34.6	1247 49.1
TCD 2013 L6 2V	mm in	1909 75.2	879 34.6	1263 49.7
TCD 2013 L6 4V	mm in	1865 73.4	1046 41.2	1322 52.0

Note: The engine dimensions and weights vary depending on the scope of delivery.

For more information please contact the DEUTZ AG Köln or the responsible sales partner.

