

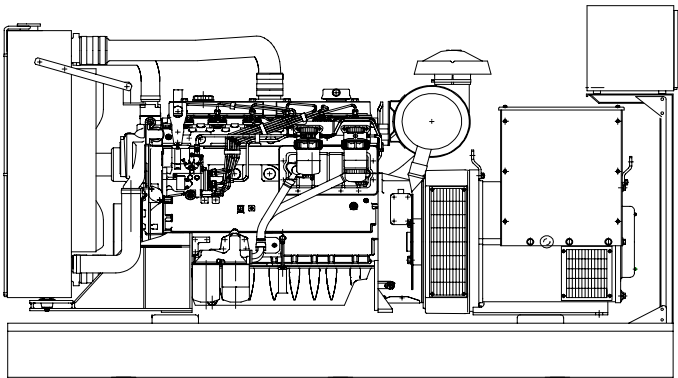

Perkins 1006TAG diesel engine

Mecc Alte ECP34-2L/4 alternator



### Standard Generator Features

- ◊ AMF, Automatic mains failure unit
- ◊ Heavy duty type, 6 cylinder, water cooled engine
- ◊ 50°C tropical type radiator
- ◊ Starter motor
- ◊ Lead acid battery
- ◊ Charging alternator
- ◊ Battery charge redressor
- ◊ Heavy duty, brushless type alternator
- ◊ Base frame with anti-vibration units
- ◊ Industrial type silencers
- ◊ Flexible exhaust compensator
- ◊ Block water heater unit
- ◊ Control panel with digital-automatic main control module
- ◊ Fan, fan drive, charging alternator drive and all rotating parts covered
- ◊ Radiator matrix covered by metal mesh against the mechanical damages
- ◊ Fabricated and welded steel base frame
- ◊ Anti-vibration mountings
- ◊ Engine and alternator manufacturer test reports
- ◊ Factory load, performance and function tests

### Optional Features

- ◊ Automatic load transfer panel
- ◊ Automatic synchronization and power sharing systems
- ◊ Soundproof canopy
- ◊ Container type enclosures
- ◊ Road trailer
- ◊ Job-site trailer
- ◊ Protection circuit breaker
- ◊ Air start
- ◊ Remote type radiator
- ◊ Base fuel tank
- ◊ External type fuel tank
- ◊ Automatic fuel transfer system
- ◊ Residential silencer



Model	Standby		Prime	
	kVA	kW	kVA	kW
<b>CJ150PC</b>	<b>156</b>	<b>125</b>	<b>141</b>	<b>113</b>

## Perkins 1006TAG Engine

### Standard Features

#### Economic Power

- ◊Single side servicing for reduced service time and cost.
- ◊Unique Fastarm combustion system enables high power output plus low fuel consumption.
- ◊Electronic governor gives close control

#### Clean, Efficient Power

- ◊Operator and environmentally friendly with low noise, rapid startability and low emissions that satisfy **TA Luft** requirements.

#### Durable Power

- ◊Maximum cooling efficiency is provided by gear driven water pump and independent fan drive.
- ◊Leak free operation is ensured by Viton crankshaft seals and sophisticated controlled swell joints, giving protection in the toughest conditions.
- ◊Inserted valve seats, oil spray cooled pistons and compact plate cooler give enhanced engine life.

#### Reliable power

- ◊Wherever a Perkins' Electropak engine is put into service, it will never be far from the support provided by a global network of 4000 distributors and dealers, all backed by a part distribution centre giving 24 hours service, 365 days a year.

### Technical Specifications

Manufacturer	PERKINS
Model	1006TAG
Type	4 cycle, water-cooled, diesel engine
Number of cylinders	6
Cylinder arrangement	Vertical In-line
Displacement, Liters	5.99
Bore X Stroke, mm	100 X 127
Compression Ratio	17.0:1
Combustion System	Direct injection
Aspiration	Turbocharged, air to air charge cooled
Rotation	Clockwise viewed from the front
Gross engine power, kWb	141
Fan Power, kWm	7.5
BMEP gross, bar	19.64
Combustion air flow, m <sup>3</sup> / min	8.78
Exhaust gas temp.(after turbo), °C	585
Exhaust gas flow (after turbo),m <sup>3</sup> / min	25.71
Mean piston speed, m / s	6.35

### Cooling System

Type	Tropical, heavy duty type
Ambient temperature, °C	50
Engine+Radiator coolant cap., Liters	37.22
Pressure cap setting, kPa	68.9
◊Thermostat controlled cooling system with gear driven water pump.	
◊Fan drive and 25" pusher fan	
◊Radiator and piping with fan guards incorporating air-to-air charge cooler.	

Model	Standby kW		Prime kW	
	Gross	Net	Gross	Net
<b>1006TAG</b>	<b>141</b>	<b>133.5</b>	<b>128.4</b>	<b>121</b>

### Lubricating System

Type	Pressurized
Capacity, Liters	19
Lub oil pressure (min), kPa	300-340
◊Flat bottomed aluminium fan	
◊Spin-on full flow oil filters	
◊Oil cooler	

### Fuel System

Type of injection system	Direct injection
Fuel atomiser	Bosch/RSU/4 hole (0.35 mm diameter)
Fuel injection Pump	Rotary/Stanadyne DB4
Delivery/hour at 1500rev/min, Liters	122.4
Governor type	Electronic, Perkins LCS2
◊Electronic governor speed control to ISO5514 classA0, ISO3046-4M3	
◊Rotary type fuel injection pump	
◊Twin spin-on full flow oil filters	
◊Cold start aid	

### Electrical System

Alternator	12 Volt, 55 Amp
Starter motor (DC)	12 Volt
◊Oil pressure switch and coolant temperature switch	
◊12 volt shut off solenoid energised to run	

### Fuel Consumption

liters per hour		
	%110 Load	34.6 L
	%100 Load	31.5 L
	%75 Load	24.1 L
	%50 Load	16.5 L
grams per kWh		
	%110 Load	206 g/kWh
	%100 Load	206 g/kWh
	%75 Load	210 g/kWh
	%50 Load	215 g/kWh

## Mecc Alte ECP34-2L/4

### Standard Features

#### Range

The ECO generators are available with a 50/60 Hz frequency, either with 2 poles ranging from 8 to 114 KVA or with 4 poles ranging from 6.5 to 3,000 KVA, with a single or double support. In order to couple them with the prime mover it is possible to choose among a wide range of flanges and couplings.

#### Mechanical Structure

The robust mechanical structure permits easy access to the connections and components during routine and extraordinary maintenance check-ups. The materials used for the manufacture of the mechanical structure are the following: FeP12 steel for the frame, C45 steel for the shaft and cast iron for the end-brackets.

The standard degree of protection is IP21 or IP23; upon the customer's request, other higher degrees of protection, such as IP45, IP54, etc., are available.

#### Insulation And Impregnation

Insulation is of class H standard. Impregnation is made with tropicalized epoxy resins by dipping and dripping, whilst for the high voltage parts by vacuum, so that the insulation level is always very good. In the highpower models, the stator windings undergo a further insulation. Special treatments for particular environmental conditions are available on request.

#### Regulation

The self-regulation is obtained through an electronic regulator. The regulator is fed by an auxiliary winding which guarantees an almost constant supply under any possible operating condition of the generator. The ECO series can be equipped with the new interchangeable U.V.R.6-F or S.R.7/2-G regulator, ensuring the same performance.

#### Voltage Accuracy

The voltage accuracy is  $\pm 1\%$  in static condition with any power factor and with speed variation between 5% and +30% with reference to the rated speed.

#### Voltage Regulation

The voltage can be regulated by the "VOLT" potentiometer of the electronic regulator. By connecting a 100K potentiometer in the proper terminals it is also possible to obtain a remote voltage regulation in a range of 5% of the rated voltage.

#### Standards

The entire series is manufactured according to and complies with the most common specifications such as CEI 2-3, IEC 34-1, EN 60034-1, VDE 0530, BS 4999-5000, CAN/CSA-C22.2 N°14-95 – N°100-95; special versions are available on request to meet specific specifications and regulations.

Model	Standby		Prime	
	kVA	kW	kVA	kW
<b>ECP34-2L/4</b>	<b>164</b>	<b>131</b>	<b>150</b>	<b>120</b>

### Technical Specifications

Manufacturer	Mecc Alte
Model	ECP34-2L/4
Type	4-Poles, Rotating Field, Brushless
Standby power at rated voltage, kVA	164
Efficiency, %	93,2
Power factor	0.8
Phase	3
Frequency, Hz	50
Speed, Rpm	1500
Voltage, V	380/415
Excitation	Self excited
Stator winding	12 ends
Regulation	Simplified Regulator, seventh generation
Voltage Regulator	SR7/2
Voltage Regulation, %	$\pm 1,5$
R.F.I Suppression	EN50081-1; EN50082-1; VDE0875K. For others standards apply to factory
Waveform Distors.at f. load LL/LN %	1,7 / 1,8
Waveform Distors.at no load LL/LN %	2,3 / 2,4
Rotor	with damping cage
Overspeed, Rpm	2250
Short circuit current	>300%
TIF Telephone Interference	THF < 2%
Insultion class	H
Stator Winding Resistance (20°C), $\Omega$	0,015
Rotor Winding Resistance (20°C), $\Omega$	3,577
DE bearing	6314.2RS
NDE bearing	6311.2RS
Protection class	IP 21 (other protection on request)

### Optional Equipment

- ◊Anti Condensation Heaters
- ◊Air Filters
- ◊Temperature Indication RTD's
- ◊Winding Protection Thermistors
- ◊SR7/2 AVR Simplified Regulator, seventh generation

## Control Panel

### Standard Equipments

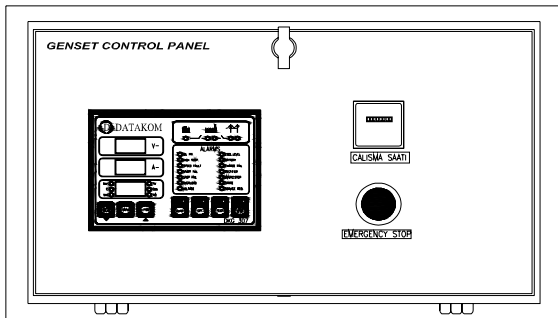

- ◊Datakom DKG307 digital automatic control module
- ◊Hourmeter
- ◊Emergency stop button

## Datakom DKG307 Control Module

### Description

◊The DKG-307 is a comprehensive AMF unit for a single generating set operating in standby mode.

◊In AUTOMATIC position, DKG-307 monitors mains phase voltages and controls the automatic starting, stopping and load transfer of the generating set in case of a mains failure and once the generator is running, it monitors internal protections and external fault inputs. If a fault condition occurs, the unit shuts down the engine automatically and indicates the failure source with the corresponding red led lamp.

◊The DKG-307 provides a comprehensive set of digitally adjustable timers, threshold levels, input and output configurations and operating sequences. The unauthorized access to program parameters is prevented by the program lock input. All programs may be modified via front panel pushbuttons, and do not require an external unit.

◊The fault conditions are considered in 2 categories as Warnings and Alarms. Measured values have separate programmable limits for warning and alarm conditions.

◊The service request indicator lamp turns on at the expiration of either engine hours or time limits.

◊It is possible to monitor the operation of the system locally or remotely with the WINDOWS based PC utility program.

◊The unit is designed for front panel mounting. It is fitted into the cut-out with the steel spring removed. Connections are made with 2 part plug and socket connectors.

### Pushbutton Controls

STOP / START  
 AUTO, TEST, MANUAL  
 LCD PAGE

### Features

- Automatic mains failure with genset control and protection
- Remote Start operation capability
- Analogue temperature and oil pressure inputs
- Genset KW and Power Factor measurement
- Engine hours run counter
- Periodic maintenance request display
- 165 programmable parameters
- Battery backed-up real time clock
- Weekly operation schedule programs
- Daily, weekly, monthly exerciser
- Event logging with time stamp
- Statistical counters
- Serial RS-232 data output for telemetry on PC
- Free MS-Windows remote monitoring SW
- Configurable analogue inputs: 2
- Configurable digital inputs: 7
- Configurable relay outputs: 2
- Output expansion capability
- Small dimensions (155x115x48mm)

### Input Functions display on LCD

Generator Volts	Volts L1-N, L2-N, L3-N
Generator Volts	Volts L1-L2, L2-L3, L3-L1
Generator Amps	Amps L1, L2, L3
Generator Frequency	Hz
Mains Volts	Volts L1-N, L2-N, L3-N
Mains Volts	Volts L1-L2, L2-L3, L3-L1
Mains Frequency	Hz
Engine Speed	RPM
Plant Battery Volts	Volts
Engine Hours Run	Hour
Generator total power	kVA L1, L2, L3,total
Generator total power	kW L1, L2, L3,total
Generator power factor	Cosφ L1, L2, L3,total

### Optional Input Functions

Engine Oil pressure	kPa
Fuel level	%
Engine Temperature	°C

### Alarm Channels

- Under/over generator voltage
- Over-current
- Under/over generator frequency
- Under/over speed
- Charge fail
- Emergency stop
- Low oil pressure
- High engine temperature
- Fail to start
- Low/high DC battery voltage
- Reverse power
- Generator phase rotation error
- Generator short-circuit protection
- Loss of speed sensing signal
- Mains out of limits

## Model Codes and General Information

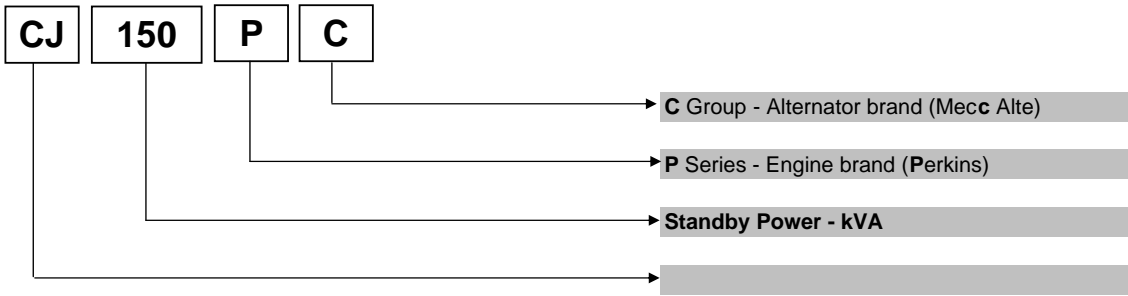

### Perkins 1000 Series Diesel Engine

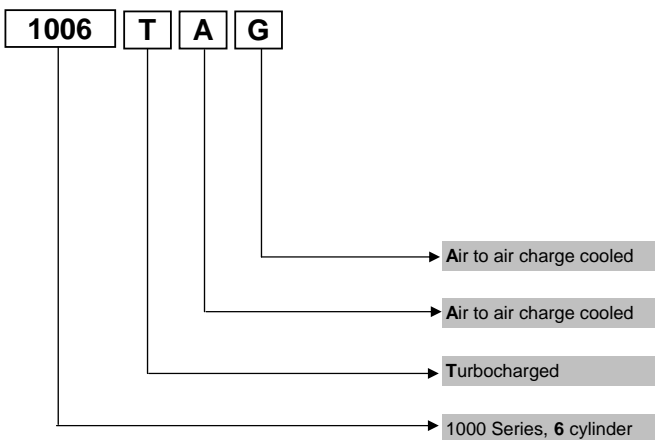

### Information

#### Power Ratings

**Standby power rating** is for the supply of emergency power at variable load for the duration of the non-availability of the mains power supply. No overload capacity is available at this rating. A standby rated engine should be sized for an average load factor of 80% based on published standby rating for 500 operating hours per year. Standby ratings should never be applied except in true emergency power failure conditions.

**Prime power rating** is available for unlimited hours per year with a variable load of which the average engine load factor is 80% of the published power rating, incorporation of a 10% overload for 1 hour in every 12 hours of operation which permitted

**Continuous power rating** is available for continuous full load operation. No overload is permitted.

Acc. to ISO 3046/1, BS 5514, DIN6271

### Mecc Alte Alternator

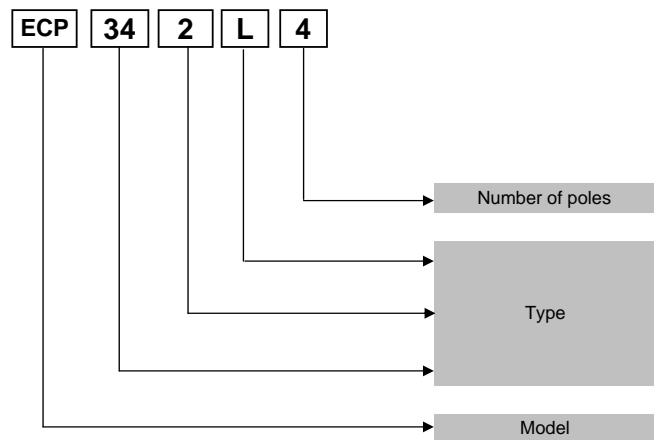

### Electric Formulas

Values	Formula	
kWe	$kW_m \times E$	
kWe	$(U \times I \times 1.73 \times pf) / 1000$	$kVA \times pf$
kVA	$(U \times I \times 1.73) / 1000$	$kWe / pf$
I (Amp)	$(kWe \times 1000) / (U \times 1.73 \times pf)$	$(kVA \times 1000) / (U \times 1.73)$
Frequency	$(Rpm \times N^\circ Pole) / (2 \times 60)$	
Rpm	$(2 \times 60 \times Frequency) / N^\circ Pole$	

**kW<sub>m</sub>**: Mechanical Power

**kW<sub>e</sub>**: Electrical Power

**pf**: Power factor

**E**: Alternator efficiency

**I**: Current (A)

**U**: Voltage (V)

**kVA**: Power

**Rpm**: Revolutions per minute

## General Dimensions

### Standard Generator

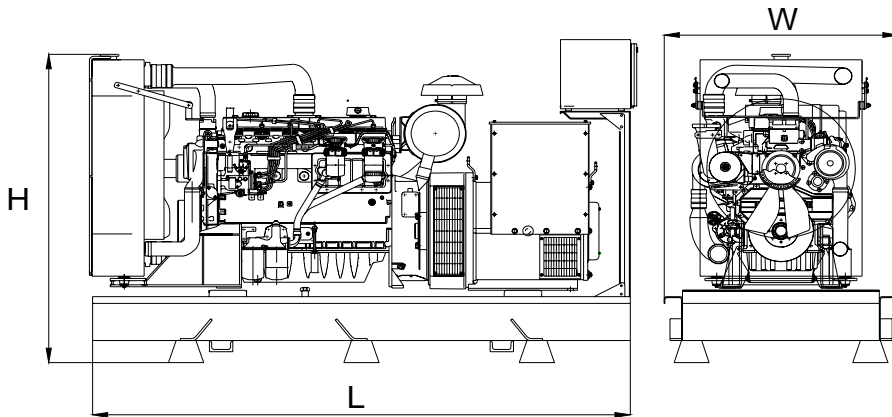

<b>Length, L</b>	2,3 m
<b>Height, H</b>	1,5 m
<b>Width, W</b>	1 m
<b>Weight, Total</b>	1350 kg

### Generator with Soundproof Canopy

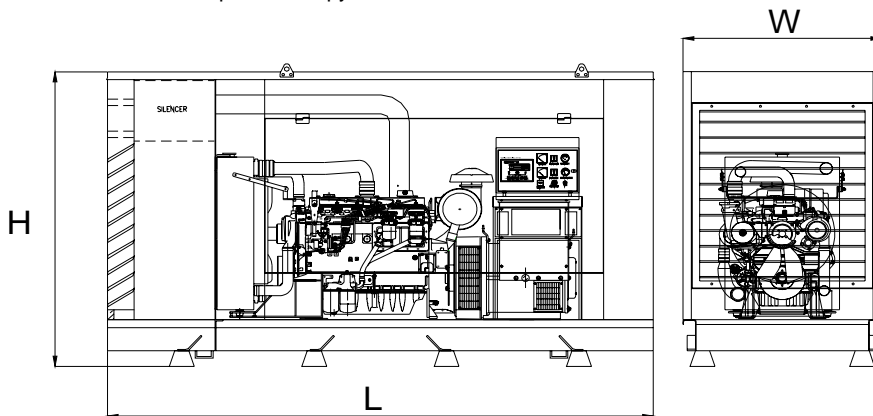

<b>Length, L</b>	3,3 m
<b>Height, H</b>	2 m
<b>Width, W</b>	1,2 m
<b>Weight, Total</b>	1850 kg

### Generator Room Layout

