

ژنراتور : MTU

موتور دیزل : MTU

Standby		Prime		دیزل ژنراتور
KVA	KW	KVA	KW	
1133	906	1030	824	



موتور دیزل

Manufacturer	MTU	تولید کننده
Model	16V2000G65TB	مدل
Number of cylinders	16	تعداد سیلندر ها
Cylinder arrangement	vertical	آرایش سیلندر ها
Displacement , Liters	1.99	جا به جایی
Bore × Stroke , mm	130× 150	قطر سیلندر × کورس پیستون
Compression Ratio	16:1	نسبت تراکم
Aspirating m ³ /min	66	سیستم تنفس
Gross engine power, kWb	824	قدرت ناخالص موتور
Fuel Consumption At 100% of power rating L/hr	214	مصرف سوخت در 100% بار
Fuel Consumption At 75% of power rating L/hr	158	مصرف سوخت در 75% بار
Fuel Consumption At 50% of power rating L/hr	108	مصرف سوخت در 50% بار
Exhaust gas temp.(after turbo) , °C	530 °	دمای گاز خروجی از اگزوز

ژنراتور

Manufacturer	MTU	تولید کننده
Model	575RSL7074	مدل
Standby power at rated voltage ,KVA	1133	توان standby در ولتاژ نامی
Power factor	0.8	ضریب قدرت
Phase	3	فاز
Frequency, Hz	50	فرکانس
Speed, Rpm	1500	سرعت
Voltage, V	380	ولتاژ
Voltage Regulator	Three phase sensing	رگولاتور ولتاژ
Voltage Regulation, %	±0.25%	تنظیم ولتاژ
Over speed, Rpm	2250	مداکثر سرعت مجاز
Insulation class	H	کلاس عایق
Connection	6 LEAD HI WYE	اتصال
Protection class	IP23	کلاس حفاظتی

DIESEL GENERATOR SET WATER CHARGE-AIR COOLING

1030kVA/50 Hz/Prime Power (Fuel Consumption Optimized)
380 - 415V



Optional equipment shown. Standard equipment may vary.

BENEFITS

- // Low installation costs
- // Best fuel consumption values
- // Long maintenance intervals
- // Best-in-class reliability and availability
- // Lifting vertically or with diagonal pull
- // Compact design

SYSTEM RATINGS^①

Prime Power	MTU 16V2000 DS1140	MTU 16V2000 DS1140	MTU 16V2000 DS1140
Voltage (L-L)	380V	400V	415V
Phase	3	3	3
PF	0.8	0.8	0.8
Hz	50	50	50
kW	824	824	816
kVA	1030	1030	1020
Amps	1565	1487	1419
Generator model	575RSL7074	575RSL7074	575RSL7074
Temp rise	125 °C/40 °C	125 °C/40 °C	125 °C/40 °C
Connection	6 LEAD HI WYE	6 LEAD HI WYE	6 LEAD HI WYE

^① Power available up to 40°C/400 m

CERTIFICATIONS AND STANDARDS

- // Engine-generator set is designed and manufactured in facilities certified to standards ISO 9001:2008 and ISO 14001:2004
- // Performance Assurance Certification (PAC)
 - Engine-generator set tested according to ISO 8528-5 for transient response
 - Verified product design, quality and performance integrity
 - All engine systems are type and factory tested
- // Power Rating
 - Permissible average power output during 24 hours of operation up to 75%

STANDARD EQUIPMENT^①

// Engine

Air filters
 Oil pump for draining
 Full flow oil filters
 Closed crankcase ventilation
 Jacket water pump
 Thermostats
 Exhaust manifold – dry
 Belt driven radiator fan
 Electric starting motor – 24V
 Governor – electronic isochronous
 Base – formed steel
 SAE flywheel & bell housing
 Charging alternator
 Flexible fuel connectors
 Flexible exhaust connection

// Generator

NEMA MG1, IEEE and ANSI standards compliance for temperature rise and motor
 VDE 0530, IEC 60034-1, BS4999, BS5000, CSA22.2-100, AS 1365
 Sustained short circuit current of up to 250% of the rated current for up to 10 seconds
 Self-ventilated and drip-proof IP23
 Superior voltage waveform
 Digital, volts-per-hertz regulator
 No load to full load regulation
 Brushless alternator with brushless pilot exciter
 4 Pole, rotating field
 125 °C maximum prime temperature rise
 Heavy duty shielded ball bearings with a minimum B-10 life of 40,000 hrs
 Flexible coupling
 Full amortisseur windings
 3-phase voltage sensing
 ±0.25% voltage regulation
 100% of rated load – one step according to NFPA 110
 3% maximum harmonic content

^① Represents standard product only. Consult Factory/MTU Onsite Energy distributor for additional configurations.

STANDARD FEATURES*

- // The engine-generator set complies to G3
- // Engine generator set tested according to ISO 8528-5 for transient response
- // Accepts rated load in one step as per NFPA 110
- // All engine-generator sets are type and factory tested
- // MTU Onsite Energy is a single source supplier
- // Global product support
- // 16V2000 diesel engine (31,84 Liter (1943 cu inch) displacement; 4-stroke)
- // Engine-generator resiliently mounted
- // Complete range of accessories
- // Brushless, rotating field generator (PMG excitation; 250% short circuit capability; 2/3 pitch stator windings)
- // Complete system metering
- // LCD display

APPLICATION DATA

// Engine

Manufacturer	MTU
Model	16V2000G65TB
Type	4-Stroke
Arrangement	16-V
Displacement/cylinder: l (cu inch)	1.99 (121)
Bore: mm (inch)	130 (5.1)
Stroke: mm (inch)	150 (5.9)
Compression ratio	16:1
Rated speed rpm	1500
Engine governor	Electronic isochronous
Max power: kWm (bhp)	890 (1194)
Speed regulation	±0.25%
Air filter	Dry

// Lube Oil Capacity

Total oil system: l (gal)	102 (27)
---------------------------	----------

// Electrical

Electric Volts DC	24
Cold cranking amps under -17.8 °C (0 °F)	1000

// Fuel System

Fuel supply connection size	M22x1,5 - 60°/Male
Fuel return connection size	M12x1,5 - 60°/Male
Maximum fuel lift: m (ft)	5 (16)
Recommended fuel	see MTU fluids & lubrication spec.
Total fuel flow: l/hr (gal/hr)	600 (159)

// Fuel Consumption^②

	gal/hr	l/hr	g/kwh
At 100% of power rating:	57	214	200
At 75% of power rating:	42	158	196
At 50% of power rating:	28	108	201

// Cooling/Radiator System

Water pump capacity: l/min (gpm)	667 (176)
Heat rejection to coolant: kW (BTUM)	375 (21,326)
Heat rejection to after cooler: kW (BTUM)	195 (11,089)
Heat radiated to ambient: kW (BTUM)	45 (2559)
Engine coolant capacity: l (gal)	130 (34)

// Air Requirements^③

Aspirating: m ³ /min (SCFM)	66 (2328)
--	-----------

// Exhaust System

Gas temp. (stack): °C (°F)	530 (986)
Gas volume flow temp: m ³ /min (SCFM)	177 (6250)
Maximum allowable back pressure: kPa	8.5

① Represents standard product only. Consult Factory/MTU Onsite Energy distributor for additional configurations.

② Values in accordance with ISO 3046-1. Conversion calculated with fuel density of 0.83 g/ml.

③ Air density = 1.184 kg/m³ (0.0739 lbm/ft³)

WEIGHTS AND DIMENSIONS

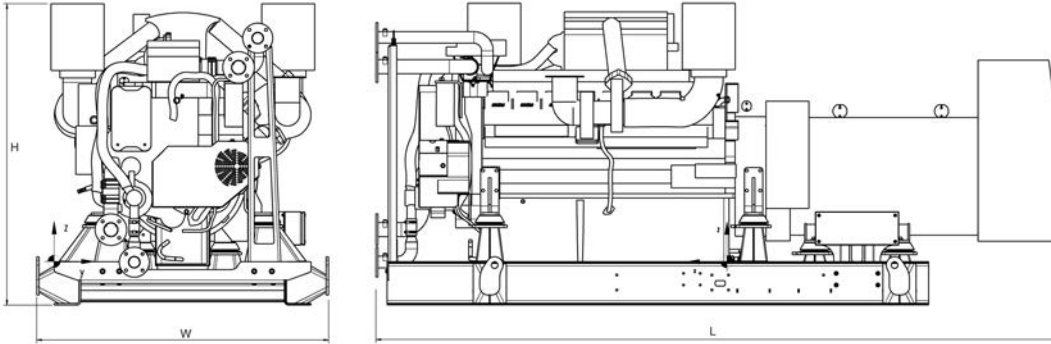

Drawing above for illustration purposes only, based on a standard open power 400 Volt engine-generator set. Lengths may vary with other voltages. Do not use for installation design. See website for unit specific template drawings.

System	Dimensions (L x W x H)	Weight (dry/less tank)
Open Power Unit (OPU)	4100 x 1750 x 1809 mm (161.4 x 69 x 71.2 inch)	5945 kg (13,106 lbs)

Weights and dimensions are based on open power units and are estimates only. Consult the factory for accurate weights and dimensions for your specific engine-generator set.

SOUND DATA

// Consult your local MTU Onsite Energy distributor for sound data.

EMISSIONS DATA

// Consult your local MTU Onsite Energy distributor for emissions data.

RATING DEFINITIONS AND CONDITIONS

// Prime power ratings apply to installations where utility power is unavailable or unreliable. At varying load, the number of generator set operating hours is unlimited. A 10% overload capacity is available for one hour in twelve. Ratings are in accordance with ISO 8528-1, ISO 3046-1, BS 5514 and AS 2789. Average load factor: $\leq 75\%$.

// Deration factor:

Altitude: Consult your local MTU Onsite Energy distributor for altitude derations.

Temperature: Consult your local MTU Onsite Energy distributor for temperature derations.

Materials and specifications subject to change without notice.