

ژنراتور : Meccalte

موتور دیزل : Volvo

Standby		Prime		دیزل ژنراتور
KVA	KW	KVA	KW	
143	114	130	104	



موتور دیزل

Manufacturer	Volvo	تولید کننده
Type	TAD532GE	تیپ
Number of cylinders	4	تعداد سیلندر ها
Cylinder arrangement	In-Line	آرایش سیلندر ها
Displacement , Liters	4.76	جا به جایی
Bore × Stroke , mm	108 x 130	قطر سیلندر × کورس پیستون
Compression Ratio	17.5:1	نسبت تراکم
Aspiration	Turbocharged	سیستم تنفس
Prime Power, kW	112	قدرت موتور (Prime)
Standby Power, kW	125	قدرت موتور (Standby)

ژنراتور

Manufacturer	Meccalte	تولید کننده
Type	ECP34-1L4	تیپ
Standby power at rated voltage ,KVA	135	توان standby در ولتاژ نامی
Efficiency, %	92.8	راندمان
Power factor	0.8	ضریب قدرت
Phase	3	فاز
Frequency, Hz	50	فرکانس
Speed, Rpm	1500	سرعت
Voltage, V	380	ولتاژ
Over speed, Rpm	2250	مداکثر سرعت مجاز
Insulation class	H	کلاس عایق
Protection class	IP 21	کلاس حفاظتی

VOLVO PENTA GENSET ENGINE

TAD532GE

1500 rpm, 129 kW (175 hp) – 1800 rpm 136 kW (185 hp)

The TAD532GE is a powerful, reliable and economical Generating Set Diesel Engine.

Durability & low noise

Designed for easiest, fastest and most economical installation. Well-balanced to produce smooth and vibration-free operation with low noise level.

To maintain a controlled working temperature in cylinders and combustion chambers, the engine is equipped with piston cooling. The engine is also fitted with replaceable cylinder liners and valve seats/guides to ensure maximum durability and service life of the engine.

Low exhaust emission

The state of the art, high-tech injection and charging system with low internal losses contributes to excellent combustion and low fuel consumption.

The TAD532GE is certified for EU Stage 2 exhaust emission regulations.

Easy service & maintenance

Easily accessible service and maintenance points contribute to the ease of service of the engine.

Technical description

Engine and block

- Optimized cast iron cylinder block with optimum distribution of forces
- Piston cooling for low piston temperature and reduced ring temperature
- Drop forged steel connecting rods
- Crankshaft hardened bearing surfaces and fillets for moderate load on main and big-end bearings
- Keystone top compression rings for long service life
- Replaceable valve guides and valve seats
- Three PTO positions at flywheel end
- Lift eyelets
- Flywheel housing with connection acc. to SAE 2
- Flywheel for flexible coupling and friction clutch
- Transport brackets

Lubrication system

- Full flow disposable spin-on oil filter, for extra high filtration
- Rotary displacement oil pump driven by the crankshaft
- Deep centre oil sump, 30° inclination
- Oil filler on top
- Oil dipstick, short in front
- Integrated full flow oil cooler, side-mounted

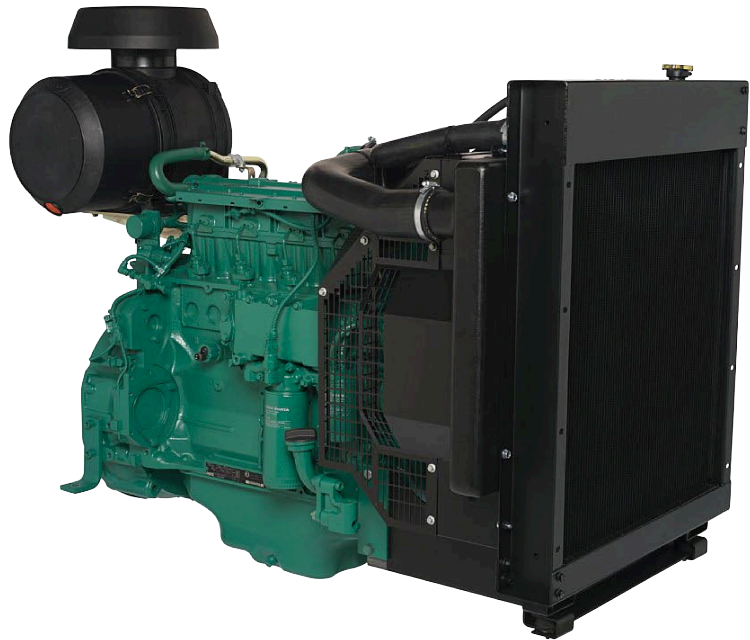

Features

- Electronic governing, EDC 4
- CAN bus communication
- Compact design
- High power to weight ratio
- Emission compliant
- Noise optimized engine design
- A wide selection of optional equipment and power settings

Fuel system

- Six hole fuel injection nozzles
- Electronic governor with smoke limiter function
- Washable fuel prefilter with water separator
- Rotary low-pressure fuel pump
- Fine fuel filter of disposable type

Intake and exhaust system

- Connection flange for exhaust line
- Turbo charger, centre low with exhaust flange
- Closed crankcase ventilation
- Heater flange in charge air inlet (without power relay)

Cooling system

- Belt driven, maintenance-free coolant pump with high degree of efficiency
- Efficient cooling with accurate coolant control through a water distribution duct in the cylinder block

- Reliable thermostat with minimum pressure drop
- Cooling water pipe, inlet and outlet
- Fan hub
- Cooling package

Electrical system

- 12 V electrical system
- Alternator 55A / 12V, low left
- Starter motor, 3.1 kW / 12V, single pole
- ECU (without high altitude sensor) control and monitoring of oil pressure, coolant temperature, coolant level, charge air pressure, engine rpm and fuel temperature compensation
- Engine wiring

**VOLVO
PENTA**

TAD532GE

Technical Data

General

Engine designation	TAD532GE	
No. of cylinders and configuration	in-line 4	
Method of operation	4-stroke	
Bore, mm (in.)	108 (4.25)	
Stroke, mm (in.)	130 (5.12)	
Displacement, l (in ³)	4.76 (290)	
Compression ratio	17.5:1	
Dry weight, kg (lb)	575 (1268)	
Wet weight, kg (lb)	606 (1336)	

Performance	1500 rpm	1800 rpm
with fan, kW (hp) at:		
Prime Power	112 (153)	115 (157)
Standby Power	125 (170)	129 (176)

Lubrication system	1500 rpm	1800 rpm
Oil consumption, liter/h (US gal/h) at:		
Prime Power	0.08 (0.021)	0.08 (0.021)
Standby Power	0.08 (0.021)	0.08 (0.021)
Oil system capacity incl filters, liter	13	

Fuel system	1500 rpm	1800 rpm
Specific fuel consumption at:		
Prime Power, g/kWh (lb/hph)		
25 %	239 (0.388)	261 (0.423)
50 %	213 (0.345)	224 (0.364)
75 %	210 (0.340)	218 (0.353)
100 %	214 (0.346)	222 (0.359)
Standby Power, g/kWh (lb/hph)		
25 %	228 (0.370)	243 (0.393)
50 %	210 (0.340)	218 (0.354)
75 %	209 (0.339)	218 (0.354)
100 %	216 (0.350)	225 (0.365)

Intake and exhaust system	1500 rpm	1800 rpm
Air consumption at 27°C, m ³ /min (cfm):		
Prime Power	7.55 (267)	9.0 (318)
Standby Power	8.03 (284)	9.6 (339)
Max allowable air intake restriction, kPa (In wc)	3.5 (14.1)	3.5 (14.1)
Heat rejection to exhaust, kW (BTU/min) at:		
Prime Power	90 (5118)	99 (5630)
Standby Power	104 (5914)	116 (6597)
Exhaust gas temperature after turbine, °C (°F) at:		
Prime Power	507 (945)	484 (904)
Standby Power	532 (990)	528 (983)
Max allowable back-pressure in exhaust line, kPa (In wc) at:		
Prime power	5 (20.1)	7 (28.1)
Standby Power	3 (12.0)	3 (12.0)
Exhaust gas flow, m ³ /min (cfm) at:		
Prime power	21.2 (749)	24.3 (857)
Standby Power	23.2 (818)	27.6 (973)

Cooling system	1500 rpm	1800 rpm
Heat rejection radiation from engine, kW (BTU/min)		
Prime Power	12 (683)	13 (739)
Standby Power	13 (739)	14 (797)
Heat rejection to coolant kW (BTU/min)		
Prime Power	56 (3207)	61 (3475)
Standby Power	63 (3566)	68 (3873)
Fan power consumption, kW (hp)	8 (7)	8.7 (12)

Standard equipment

Engine

- Automatic belt tensioner
- Lift eyelets

Flywheel

- Flywheel housing with conn. acc. to SAE 2
- Flywheel 10" and 11.5" disc

Vibration dampers

Engine suspension

- Fixed front suspension

Lubrication system

- Oil dipstick
- Full-flow oil filter of spin-on type
- By-pass oil filter of spin-on type
- Oil cooler, side mounted
- Low noise oil sump

Fuel system

- Fuel filters of disposable type
- Pre-filter with water separator

Intake and exhaust system

- Air filter with replaceable paper insert
- Air restriction indicator
- Air cooled exhaust manifold
- Connecting flange for exhaust pipe
- Exhaust flange with v-clamp
- Turbo charger, low left side
- Crankcase ventilation

Cooling system

- Tropical radiator incl intercooler
- Gear driven coolant pump
- Fan hub
- Pusher fan
- Fan guard
- Belt guard

Control system

- Engine Diesel Control 4 (EDC4) with CAN-bus interface SAE J1939 and stand alone interface

Alternator

- Alternator 55A / 12 V

Starting system

- Starter motor, 3.1 kW, 12 V

Instruments and senders

- Temp.- and oil pressure for automatic stop/alarm 103°C

Engine Packing

- Plastic wrapping

- optional equipment or not applicable
- included in standard specification

Dimensions TAD532GE

Not for installation

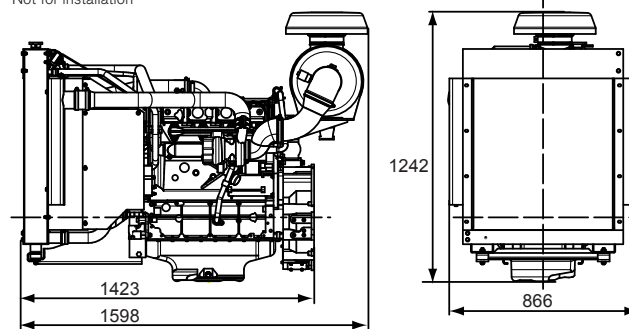

Note! Not all models, standard equipment and accessories are available in all countries. All specifications are subject to change without notice. The engine illustrated may not be entirely identical to production standard engines.

Power Standards

The engine performance corresponds to ISO 3046, BS 5514 and DIN 6271. The technical data applies to an engine without cooling fan and operating on a fuel with calorific value of 42.7 MJ/kg (18360 BTU/lb) and a density of 0.84 kg/liter (7.01 lb/US gal), also where this involves a deviation from the standards. Power output guaranteed within 0 to +2% at rated ambient conditions at delivery. Ratings are based on ISO 8528.

Engine speed governing in accordance with ISO 3046/IV, class A1 and ISO 8528-5 class G3

Exhaust emissions

The engine complies with Tier 2 and TA-luft exhaust emission regulations.

Rating Guidelines

PRIME POWER rating corresponds to ISO Standard Power for continuous operation. It is applicable for supplying electrical power at variable load for an unlimited number of hours instead of commercially purchased power. A10 % overload capability for governing purpose is available for this rating.

MAXIMUM STANDBY POWER rating corresponds to ISO Standard Fuel Stop Power. It is applicable for supplying standby electrical power at variable load in areas with well established electrical networks in the event of normal utility power failure. No overload capability is available for this rating. 1 hp = 1 kW x 1.36

Information

For more technical data and information, please look in the Generating Set Engines Sales Guide.

VOLVO PENTA

AB Volvo Penta
SE-405 08 Göteborg, Sweden
www.volvopenta.com



GENERATOR TYPE ECP 34-1L/4 A

Document : DS274A/1

issue 002 date 27/01/2014

Electrical Characteristics										
Frequency	Hz	50				60				
Voltage (series star)	V	380	400	415	440	415	440	460	480	
Rated power class H	kVA	135	135	135	114	140	150	162	162	
	kW	108	108	108	91	112	120	130	130	
Rated power class F	kVA	121	121	121	103	125	135	146	146	
	kW	97	97	97	82	100	108	117	117	
Regulation with DSR		±1% with any power factor and speed variations between -5% +30%								
Insulation class		H								
Execution		Brushless								
Stator winding		12 ends								
Rotor		with damping cage								
Efficiencies class H	4/4	%	92,8	92,9	92,6	92,4	94	94,5	94,7	94,8
(see graph. for details)	3/4	%	93,1	93,4	93,2	93	94,5	95	95,2	95,3
	2/4	%	91,6	91,7	91,7	91,6	93,1	93,3	93,5	93,6
	1/4	%	88,2	88,2	88,1	88	89,3	89,4	89,5	89,3
Reactances (f. l.cl. F)	Xd	%	245	222	202	161	257	250	241	222
	Xd'	%	16,8	15,4	14,4	11,5	19,5	18,0	16,8	15,4
	Xd''	%	8,1	7,6	6,9	5,4	9,7	8,9	8,1	7,6
	Xq	%	148	136	125	112	162	154	148	136
	Xq'	%	148	136	125	112	162	154	148	136
	Xq''	%	31,2	28,4	27,1	25,2	35,4	33	31,2	28,4
	X ₂	%	18,9	17,2	16,6	15,4	22,1	20,7	18,9	17,2
	X ₀	%	3,1	2,7	2,9	2,2	3,6	3,4	3,1	2,7
Short Circuit Ratio	Kcc		0,39	0,45	0,60	0,90	0,30	0,35	0,39	0,45
Time Constants	Td'	sec.	0,039							
	Td''	sec.	0,0085							
	Tdo'	sec.	1,85							
	Tα	sec.	0,0168							
Short Circuit Current Capacity		%	>300				>350			
Excitation at no load	Amp.		0,5	0,6	0,67	0,8	0,3	0,35	0,4	0,5
Excitation at full load	Amp.		2,1	2,1	2,2	2,4	2,3	2,1	2	2
Overload (long-term)		%	1 hour in a 6 hours period 110% rated load							
Overload per 20 sec.		%	300							
Stator Winding Resistance (20°C)	Ω		0,016							
Rotor Winding Resistance (20°C)	Ω		4,142							
Exciter Resistance (20 °C)	Ω		Rotor : 0,410				Stator : 15,28			
Heat dissipation at f.l.cl.H	W		8379	8254	8631	7501	7149	6984	7253	7109
Telephone Interference			THF < 2%				TIF < 40			
Radio interference			EN61000-6-3, EN61000-6-2. For others standards apply to factory							
Waveform Distors.(THD) at f. load	LL/LN %		1,7 / 1,9							
Waveform Distors.(THD) at no load	LL/LN %		2,3 / 2,5							
Mechanical characteristics										
Protection			IP 21 (other protection on request)							
DE bearing			6314.2RS							
NDE bearing			6311.2RS							
Weight of wound stator assembly	kg		152							
Weight of wound rotor assembly	kg		101,3							
Weight of complete generator	kg		467							
Maximun overspeed	rpm		2250							
Unbalanced magnetic pull at f.l.cl.F	kN/mm		5,7							
Cooling air requirement	m ³ /min		19,3				23			
Inertia Constant (H)	sec.		0,098				0,118			
Noise level at 1m/7m	dB(A)		79 / 65				83 / 69			

All technical data are to be considered as a reference and they can be modified without any notice.

This document is a propriety of Mecc Alte S.p.a..All rights reserved.

50 Hz

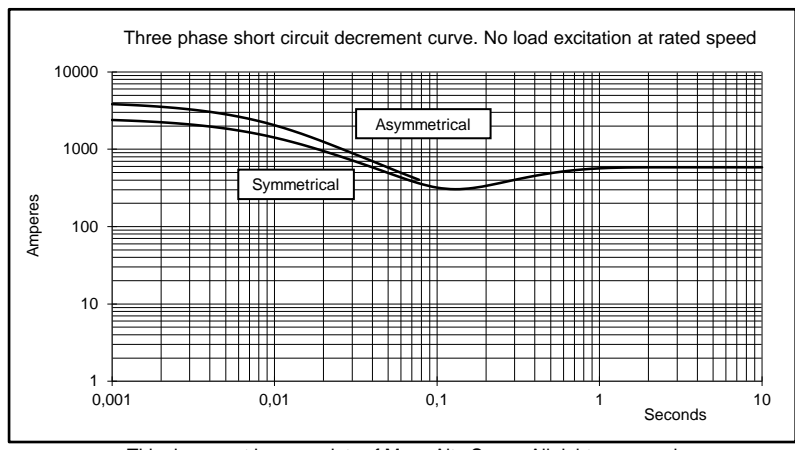
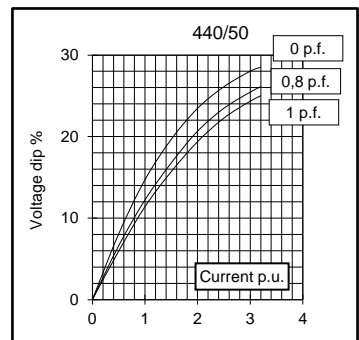
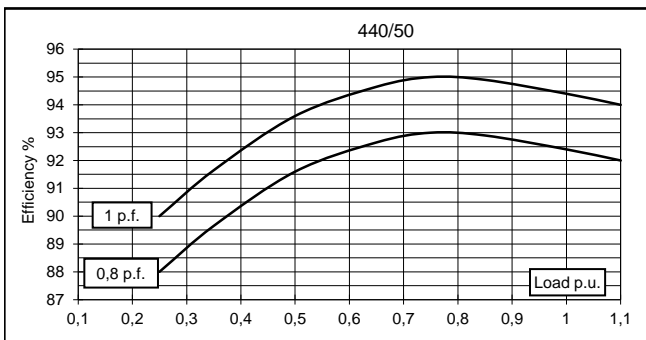
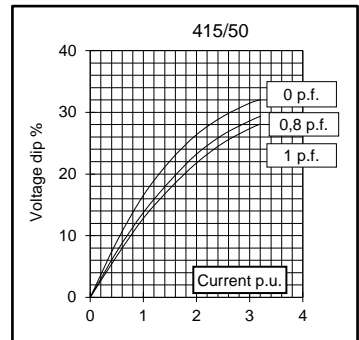
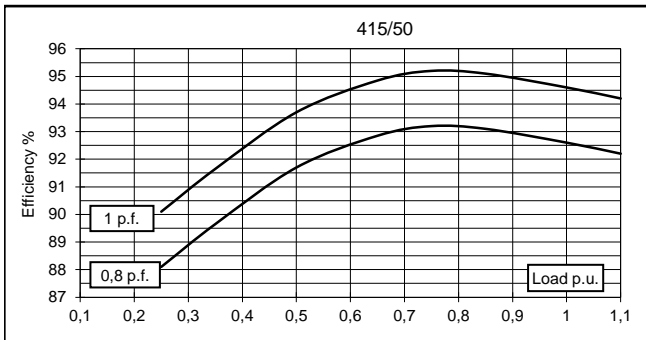
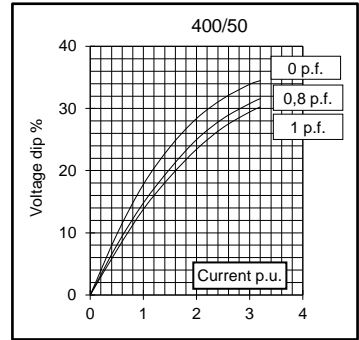
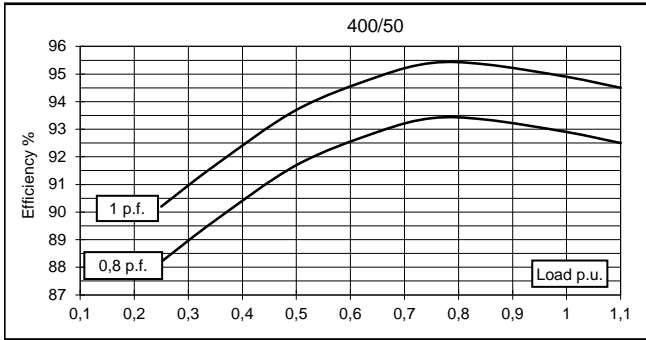
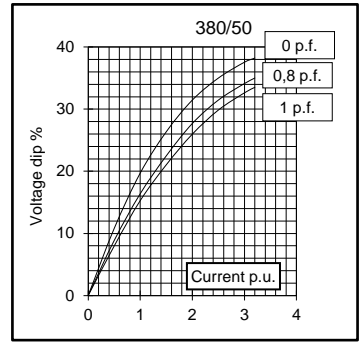
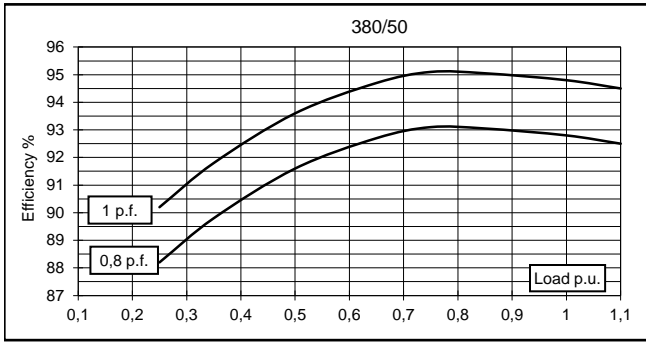

60 Hz

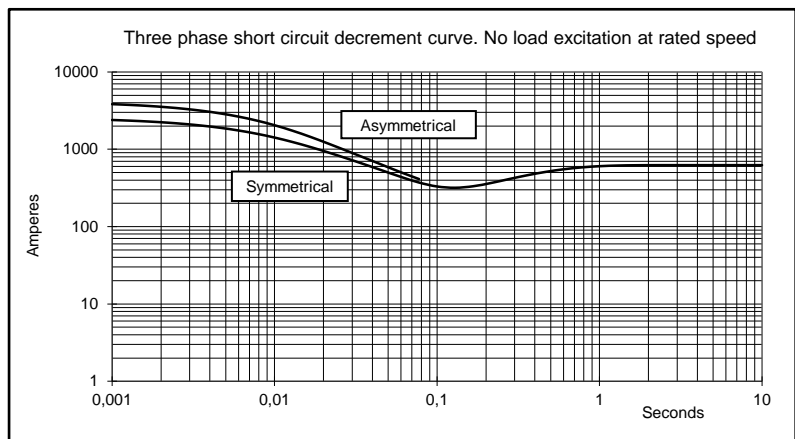
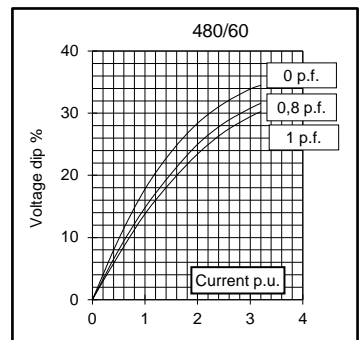
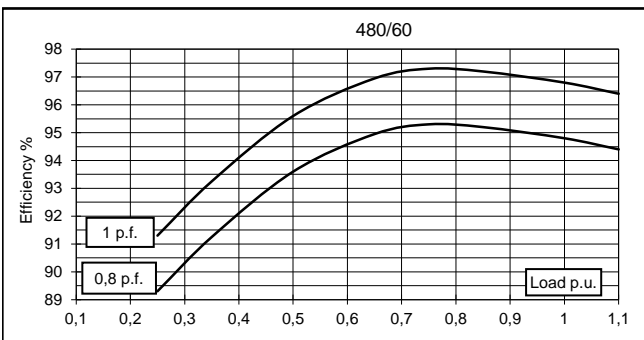
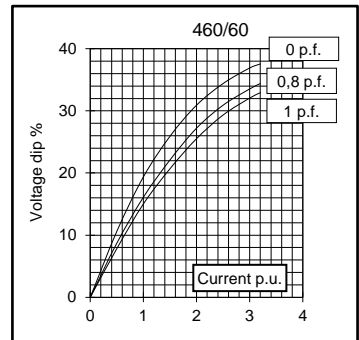
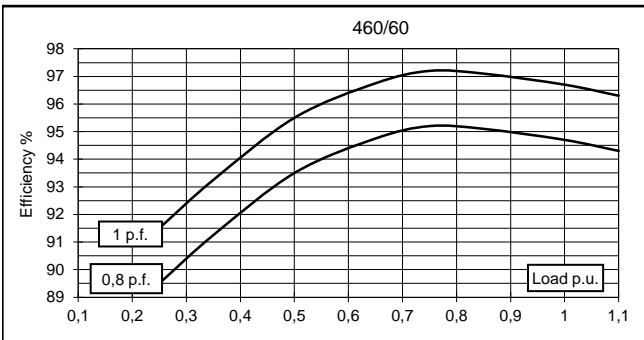
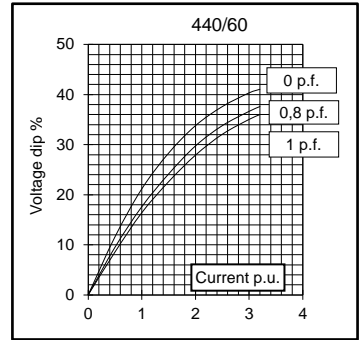
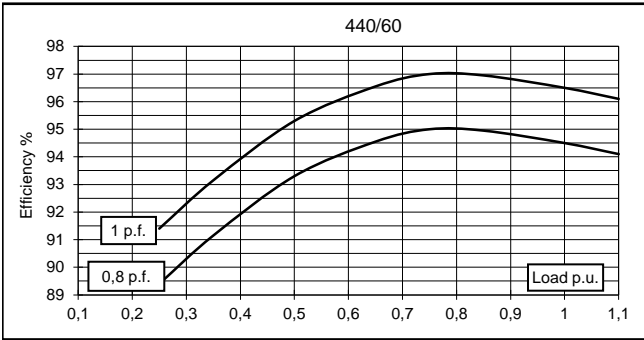
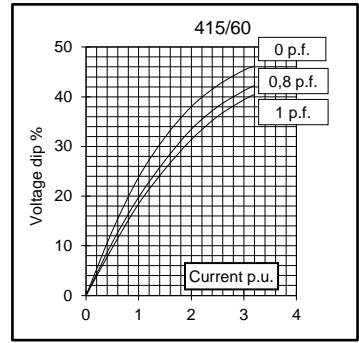
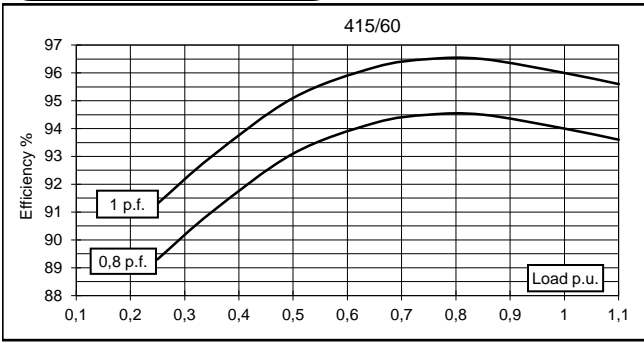

SINGLE BEARING MOMENTS OF INERTIA

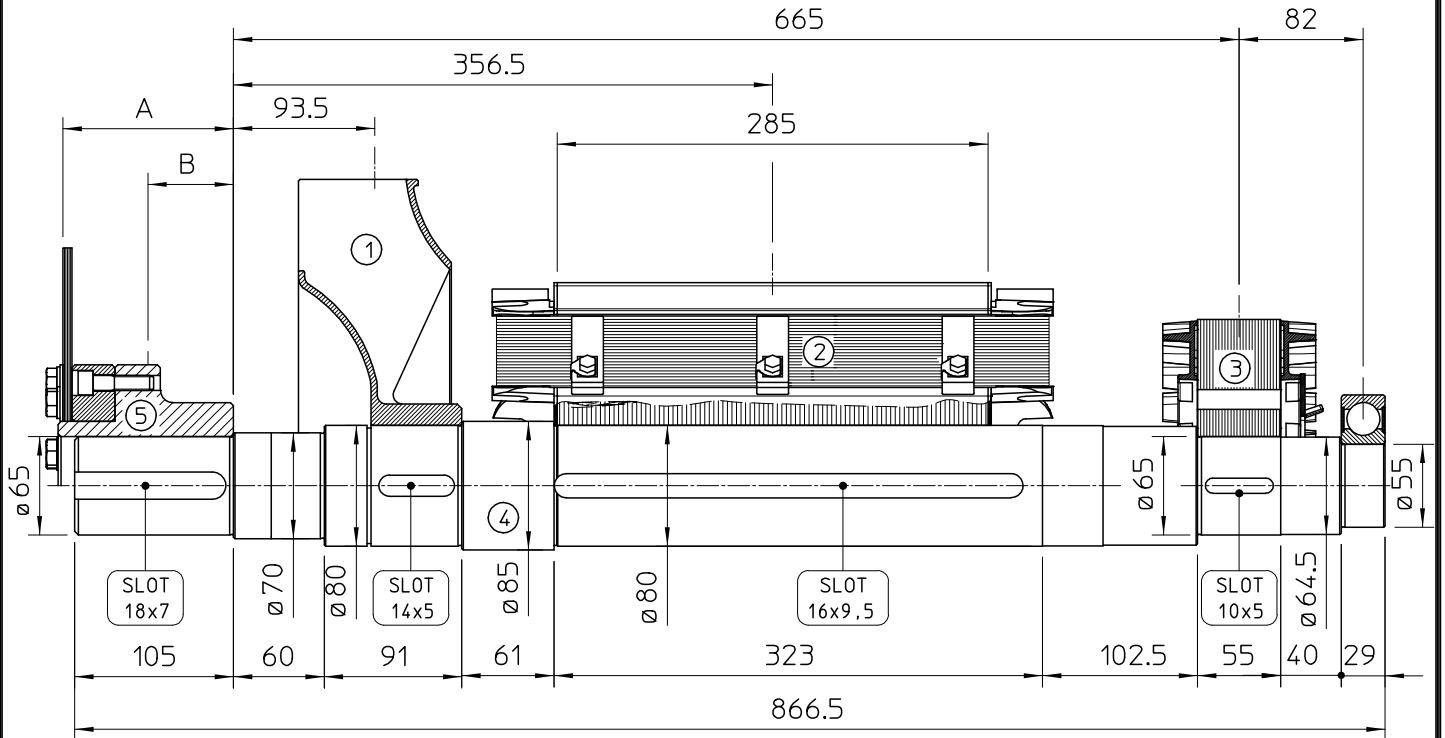

POS.	COMPONENT	WEIGHT (kg)	J (kgm ²)
1	FAN	3.6	0.0451
2	MAIN ROTOR	101.3	0.9153
3	EX. ROTOR	14.5	0.0874
4	SHAFT	29.6	0.0218
TOTAL		148.8	1.0696

SAE N°	5		SHAFTS COUPLING FLEX PLATE	
	A	B	WEIGHT kg	J kgm ²
10	112.8	35.6	13.5	0.0770
11 1/2	98.6	71.5	12.4	0.0956
14	84.4	68.6	14.8	0.2360

SINGLE BEARING DIMENSIONS

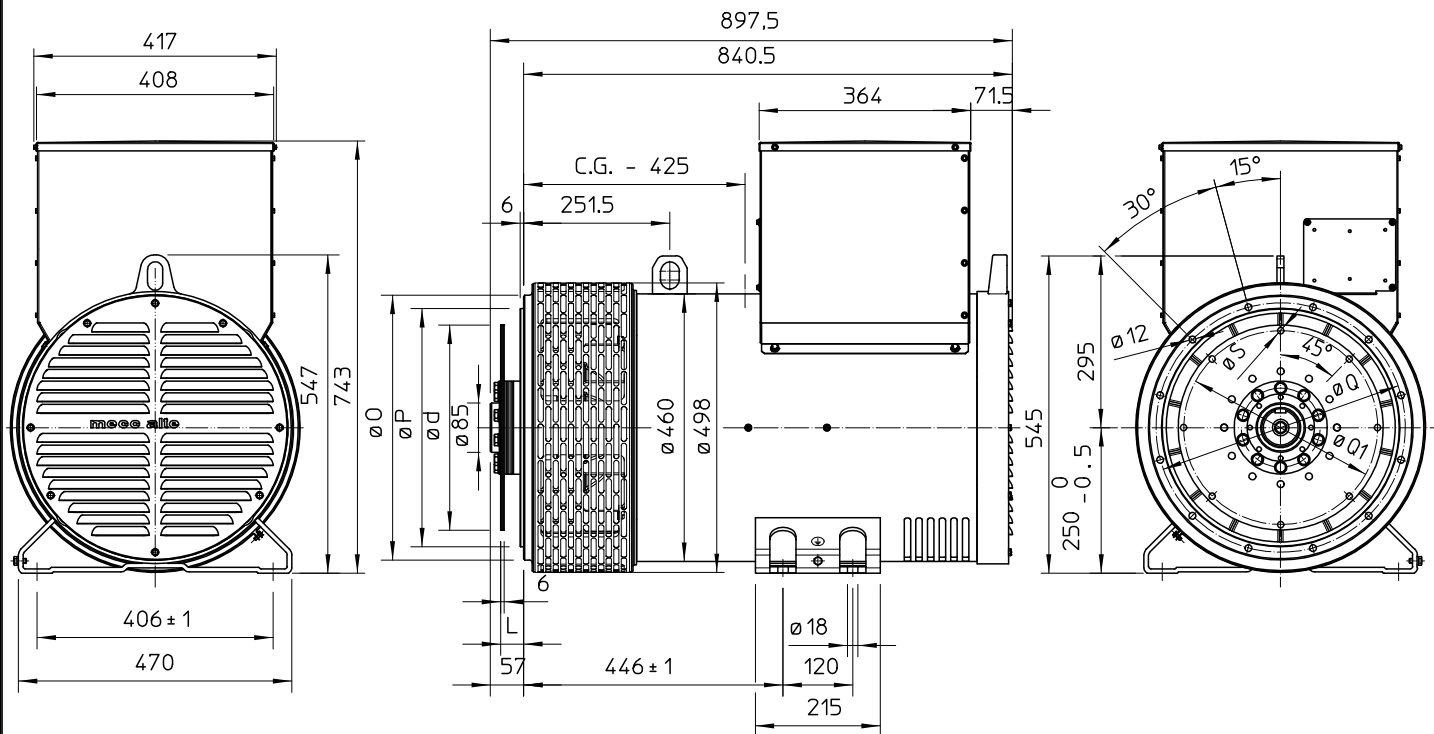

SAE N.	FLANGIA / FLANGE BRIDE / FLANSCH		
	O	P	Q
3	451	409.6	428.6
2	489	447.7	466.7
1	552	511.2	530.2

SAE N.	GIUNTI A DISCHI / DISC COUPLING DISCQUE DE MONOPALIER / SCHEIBENKUPPLUNG			
	L	d	Q1	S
10	53.8	314.32	295.27	11
11 1/2	39.6	352.42	333.37	11
14	25.4	466.72	438.15	14

C.G.= GRAVITY CENTER